

ASTRO-PHYSICS
**1200 GERMAN EQUATORIAL WITH
GTO SERVO MOTOR DRIVE**

Model GTOCP3



ASTRO-PHYSICS, INC
11250 Forest Hills Road
Rockford, IL 61115
Telephone: (815)-282-1513
Fax: (815)-282-9847
support@astro-physics.com
www.astro-physics.com

February 8, 2005

ASTRO-PHYSICS

1200 GERMAN EQUATORIAL WITH GTO SERVO MOTOR DRIVE

MODEL 1200GTO PARTS LIST – MODEL GTOCP3	4
FEATURES AND SPECIFICATIONS	4
INTRODUCTION	5
Why Polar Alignment is Important	5
Compensation for the Earth's rotation	5
ASSEMBLY DIAGRAM	6
BEFORE YOU LEAVE HOME	7
Gross Latitude Adjustment	7
Attach Pier Adapter to Pier Post (purchased separately)	8
1200 Standard Pier Adapter (part # 1200SPA)	8
1200 Rotating Pier Adapter with Azimuth Bearing (part # 1200RPA)	8
AT YOUR OBSERVING SITE	9
Assemble Pier (purchased separately)	9
Assemble Polar Axis Assembly to Pier or Tripod	9
Polar Alignment	9
Rough Polar Alignment	9
Fine Polar Alignment	10
Methods for fine polar alignment	10
Azimuth Adjustments	11
Rotating Pier Adapter with Azimuth Bearing (1200RPA)	11
Standard Pier Adapter (1200SPA)	11
Altitude Adjustment	12
Tips for Adjusting the Altitude	12
Assemble Declination Axis	13
Removing Declination Axis at the End of your Observing Session	13
Attach Mounting Plate (purchased separately)	14
Understanding the R.A. and Dec. Clutch Knobs	15
Attach Counterweight Shaft and Counterweights	15
Attach Mounting Rings and Scope (purchased separately)	16
Balancing Your Telescope	16
Fine Polar Alignment	16
SERVO MOTOR DRIVE	17
GTO Control Box – Model GTOCP3	17
R.A. and Dec. Cable Connections	17
12V Connector	17
POWER Indicator Light	18
KEYPAD Connector	18
RS-232 Connectors	18
FOCUS Connector	18
RETICLE Connector	18
AUTOGUIDER Connector	18

+6V Connector	18
N and S Switch	19
Removing the GTO Control Box From 1200 Mount	19
GTO KEYPAD OPERATION	19
PULSEGUIDE BY SIRIUS-IMAGING	19
CABLE MANAGEMENT	20
1200 Motor Cables	20
Accessory Cables	20
Example from International Space Station – Amateur Telescope (ISS-AT) Project	20
MOUNT CARE AND ALIGNMENT	22
Mount Maintenance	23
Tips and support	23
TROUBLESHOOTING	23
INSTALLATION OF ENCODERS AND ENCODER HOUSINGS -1200 MOUNT	25
Fitting Declination Encoder Housing	25
Fitting Right Ascension Encoder Housing	26
Periodic Maintenance	26

ASTRO-PHYSICS

1200 GERMAN EQUATORIAL WITH GTO SERVO MOTOR DRIVE

MODEL 1200GTO PARTS LIST – MODEL GTOCP3

- 1 Polar axis assembly (right ascension-R.A.) with Servo Box GTOCP3
- 1 Declination (Dec.) axis assembly
- 1 18.5" Stainless counterweight shaft (1.875" dia.) with washer stop and black plastic knob (knob has 5/16 thread)
- 1 Y cable – R.A. portion is 12.5" long and Dec portion is 37.5" long
- 1 D.C. power cord (cigarette lighter adapter on one end) - 8' long
- 1 GTO Keypad controller with 15' coiled cable
- 1 Keypad Protector (KEYPRO)
- 1 Hex key set
- 2 8-32 thumbscrews (substitute these for 8-32 set screws that hold GTO Servo Control Box in place, if you wish)
- 1 PulseGuide software by Sirius-Imaging on CD

In order to fully assemble your mount, you will need the following items sold separately: pier adapter (either standard or rotating), mounting plate, 10" O.D. pier, counterweights and portable rechargeable battery pack (or 110 to 12V DC converter). Several sizes and types are available for your selection. Many of these items will be discussed throughout these instructions.

Several additional options are available:

28" counterweight shaft – 27" useable length, part # M12661-A

Santa Barbara Instrument Group CCD Imaging cameras and ST-4 Autoguider or STV - if you plan to pursue CCD imaging or astrophotography

Pier accessory trays for 10" pier and support bars - handy to keep your eyepieces close at hand

Polar axis telescope - threads into the base of the polar axis assembly. Many users find a polar axis telescope useful for zeroing in on the pole quickly, particularly with telescopes that are not orthogonal to the mount.

Mounted encoders – Although you can use these with your mount, they are not necessary since the go-to functions of the mount are more accurate. The 4000 steps of the encoders, which read the position of the shaft are very coarse (324 arc seconds) while the encoder that is built into the servo motor itself is 0.05 arc seconds.

FEATURES AND SPECIFICATIONS

R.A. worm wheel:	10.3", 225-tooth aluminum
Dec worm wheel:	7.2", 225-tooth aluminum
Worm gear:	Brass
R.A. shaft:	3.35" diameter
R.A. thrust bearings:	9.5" diameter
Dec shaft:	2.36" diameter
Dec thrust bearings:	6.5" diameter
Counterweight shaft:	18.5" useable length, 1.875" diameter, stainless steel, removable
Latitude range:	21.5 - 68 degrees with or without polar scope or encoders attached
Azimuth adjustment:	Approximately 14 degrees
Setting circles:	Porter Slip Ring design, engraved
Right ascension:	4-minute increments, pointer
Declination:	1-degree increments, pointer
Motors:	Zero-cogging servo motors
Power Consumption:	0.4 amps at the sidereal rate 3 amps both motors slewing
Power requirements:	12 VDC, range 11.5 to 18V (higher voltage recommended for very cold temps and heavy loads)
Weight of mount:	Equatorial head: 81 lbs. (36.7 kg) Dec axis: 31 lbs. (14.1 kg) R.A axis: 50 lbs. (22.7 kg) Counterweight shaft: 14 lbs. (6.4 kg)

INTRODUCTION

The 1200 German equatorial was designed to meet the needs of the advanced observer who requires a mount with maximum strength and rigidity and minimum weight. The excess material in both axes has been carved out while retaining a heavily ribbed structure for internal strength and rigidity. A unique dovetail was machined into the mating surfaces of the R.A. and Dec axes. This feature allows quick and easy assembly in the field without any tools.

The DC servo motor drive with GTO computer system, including the keypad controller with its digital display screen and *PulseGuide* software offer extraordinary sophistication for today's observer. Whether you enjoy visual astronomy exclusively or plan an aggressive astrophotography or CCD imaging program, this mount will allow you to maximize your night out under the stars.

The advanced keypad features allow you to slew automatically to objects in a wide range of databases as well as any RA/Dec or Alt/Az coordinate. A large selection of common names for stars and other objects makes your selection a snap. The rapid slew rate of 5 degrees per second (1200x) allows you to locate objects very quickly and accurately. You will be very pleased with the intuitive operation of this controller. There are no complicated sequences of keystrokes to remember. It is so easy to use that even if you don't use it for a few months, you will feel at home with the keypad very quickly.

The 1200 is equally at home in a permanent observatory or as a portable mounting for remote star parties thanks to the ease with which the two axes come apart. This is the perfect mount for a large refractor, Newtonian, Cassegrain or astrograph.

In order to maximize your pleasure on your first night out, we recommend that you familiarize yourself with the assembly and basic operation of the mount indoors. The temperature will be comfortable, the mosquitoes at bay, and you'll have enough light to see the illustrations and read the manual. Please take particular note of counterbalancing, use of the clutches and operation of the keypad controller.

Why Polar Alignment is Important

Compensation for the Earth's rotation

If you were to take a long exposure photograph with Polaris (often called the north star) in the center of the field, you would discover that all stars seem to revolve around Polaris. This effect is due to the rotation of the earth on its axis. Motor driven equatorial mounts were designed to compensate for the earth's rotation by moving the telescope at the same rate and opposite to the earth's rotation. When the polar axis of the telescope is pointed at the celestial pole (polar aligned) as shown in Diagram 1, the mount will follow (track) the motions of the sun, moon, planets and stars. As a result, the object that you are observing will appear motionless as you observe through the eyepiece or take astrophotos.

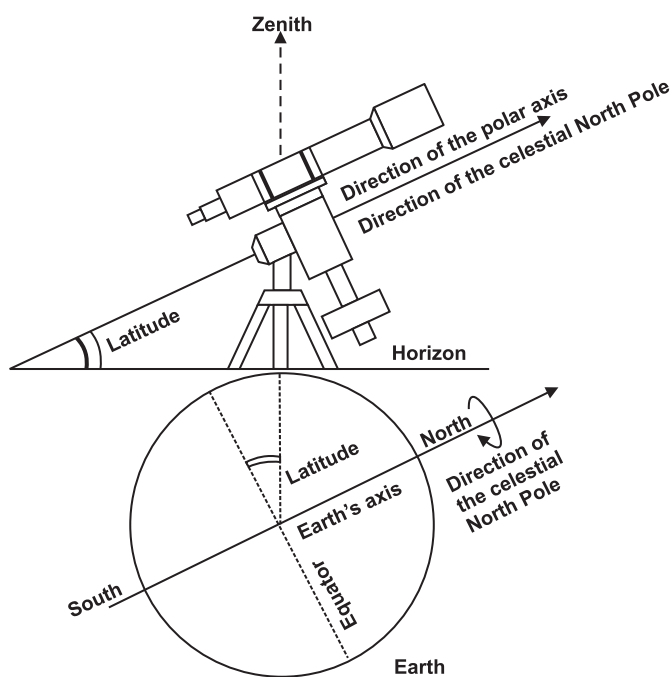

Diagram 1

ASSEMBLY DIAGRAM

Please read all instructions before attempting to set up your 1200 mount. The Model 1200 is very rugged, however like any precision instrument, it can be damaged by improper use and handling. Please refer to Diagram 2 for an illustration of the mount. The parts are labeled so that we can establish common terminology.

The following terms and abbreviations are used interchangeably in these instructions:

polar axis = right ascension axis = R.A. axis = R.A. housing

declination axis = dec. axis = dec. housing

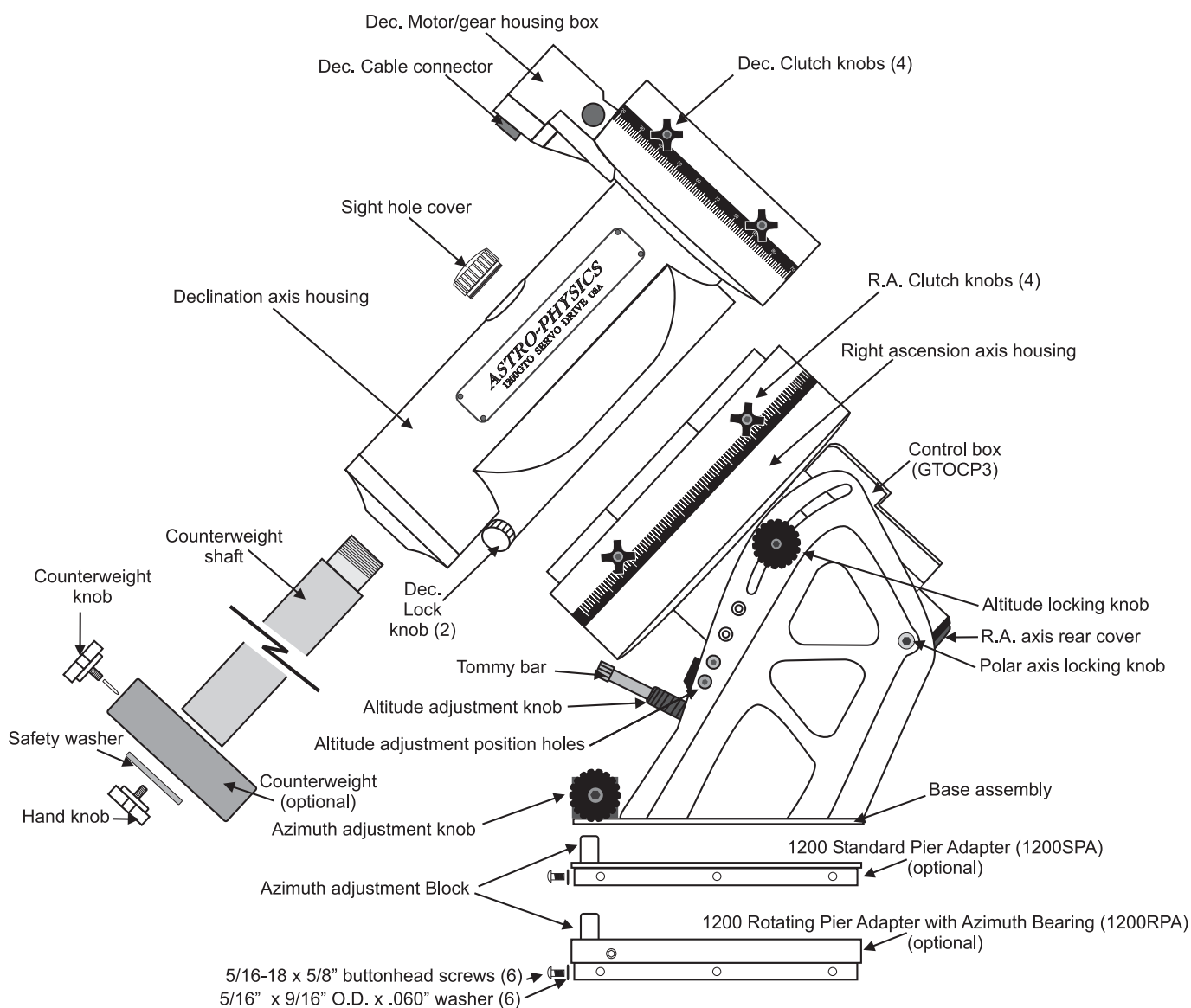

Diagram 2

BEFORE YOU LEAVE HOME

Since most of us must set up our instruments in the dark, in the cold or while battling mosquitoes, a bit of pre-planning and organization is important. There are few simple things that can be accomplished in the comfort of your home before heading outside.

Gross Latitude Adjustment

The total latitude range of the 1200 mount is approximately 21.5-68 degrees with 4 adjustment positions. Since most astronomers typically observe within one latitude range, this adjustment is made just once, if at all. Prior to shipment, we preset the mount to your latitude range for your convenience. If you travel to another observing location, determine the latitude of your observing site and make the appropriate adjustment.

The four positions for the altitude adjustments have the following approximate ranges:

- 55 degrees to 68 degrees latitude - top position
- 37 degrees to 59 degrees latitude - third position
- 28 degrees to 50 degrees latitude - second position
- 21.5 degrees to 37 degrees latitude - bottom position

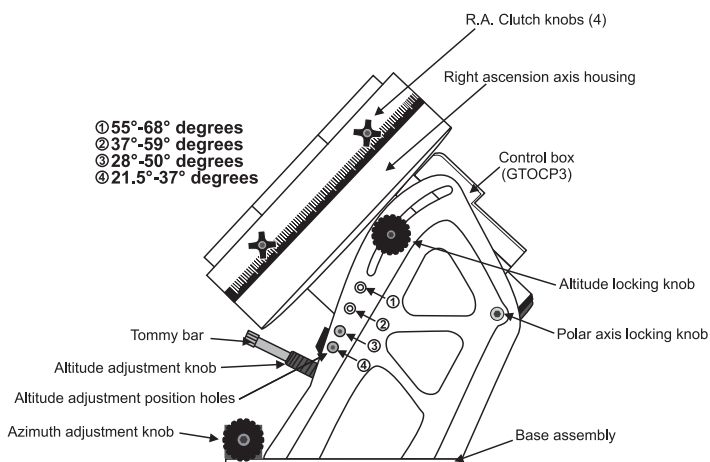

Diagram 3

How to change the position of the altitude adjuster bar

1. Use only the R.A. axis. DO NOT attempt to make these adjustments with the declination axis in place and certainly not with an instrument fully mounted.
2. Loosen both altitude-locking knobs about 1 turn.
3. Locate the side of the polar axis that does **not** have the motor/gear housing box. Loosen (about 1 turn) the polar axis pivot screw and altitude adjuster bar fixing screws on this side only. With your hand, push the polar axis upwards so that the altitude locking knobs are positioned at the top of the altitude slot (this is the maximum altitude position). Some resistance will be felt with this operation since you are pushing against the weight of the polar housing and the resistance of the remaining polar axis pivot screw (which has not been loosened).
4. Before attempting to move the altitude adjuster bar, you must tighten the altitude-locking knob on the motor/gear housing side. This will prevent any downward movement of the polar axis during positioning of the altitude adjuster bar.
5. While supporting the altitude adjuster bar, remove the two screws that support it on each side (4 screws in all), but keep the two ends of the bar in contact with the side of the mount, don't remove it completely (this tip is for your convenience).
6. Determine the latitude range that you need (refer to Diagram 3) and position the hole that is marked "A" in Diagram 5 at that location. Note that this hole is located at the rounded part of the altitude bar.
7. Attach two of the screws (one on either side of the adjuster bar), but do not tighten. Rotate the altitude adjuster bar around this pivot point until one of the other holes lines up. Insert the remaining two screws. Lightly tighten so that you still have some ability to move the bar.
8. Note that the altitude adjustment knob is attached to a threaded rod that travels through the altitude adjuster bar. Turn the knob so that the altitude adjuster bar is positioned approximately in the middle of the threaded rod. You should see about half of the threaded rod protruding from both sides of the altitude adjuster bar. This will allow you to move the mount fully within the altitude range.

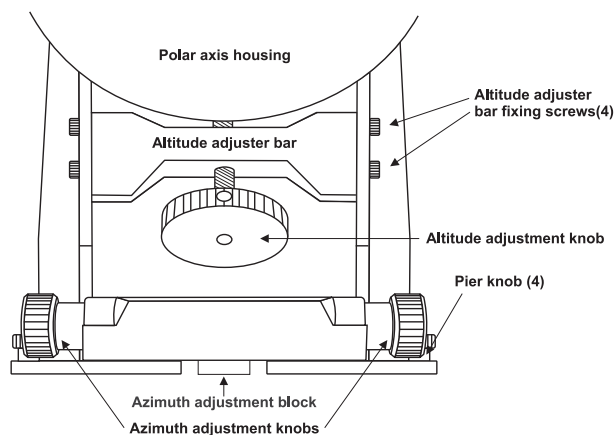
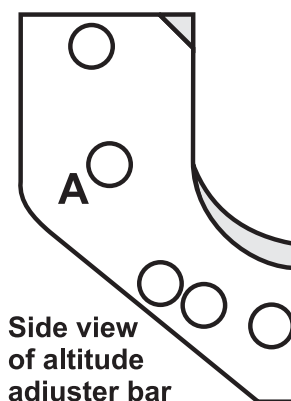

Diagram 4



Side view of altitude adjuster bar

Diagram 5

9. At the end of the threaded rod mentioned in the last step, you will see a small brass altitude adjuster thrust pad. This is the part that will come in contact with the polar axis as you ease it back into position. Loosen the altitude locking knob (motor/gear side) and lower the polar axis so that it rests comfortably on this pad. The threaded rod should be positioned at a right angle to the polar axis housing. Firmly tighten the altitude adjustment screws.
10. Turn the altitude adjustment knob to raise or lower the polar axis to your approximate observing latitude. Tighten the altitude locking knobs with finger pressure only. You do not need to tighten with the hex key.
11. Firmly tighten both polar axis pivot screws with the hex key.

Attach Pier Adapter to Pier Post (purchased separately)

If you purchased the pier from Astro-Physics, the pier adapter of the 1200 may be already attached to the top of the pier. If you are constructing your own pier or tripod, you will need to incorporate this part. Two models of the pier adapter are now available for use with the 1200 from Astro-Physics. If you have more than one pier, you may wish to purchase two adapters so that you can leave them attached permanently. These pier adapters can be used with prior versions of the 1200 mount.

1200 Standard Pier Adapter (part # 1200SPA)

The Standard Pier Adapter includes the machined flat plate, four machined aluminum lock knobs with stainless washers, the azimuth adjuster block, six 5/16"-18 x 5/8" side bolts and washers. All machined parts are black anodized. The Standard Pier Adapter was designed to fit into a 10" x 0.094" wall tube with 6 screws threaded into the side or bolted onto a flat surface by using the four countersunk thru-holes (pier adapters from early production runs may not have the thru-holes).

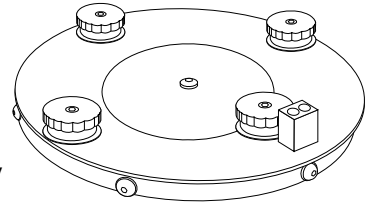

1200 Rotating Pier Adapter with Azimuth Bearing (part # 1200RPA)

The Rotating Pier Adapter rotates on a bearing surface for ultra-smooth operation. It includes a machined flat plate assembly with four machined aluminum lock knobs and stainless washers, the azimuth adjuster block and six 5/16"-18 x 5/8" side bolts with washers. This adapter allows you to lock the mount down with no need to loosen the base during azimuth adjustment. Observers who use the 1200 as a portable mount and set up frequently will find this especially useful. Unlike the standard pier adapter, the rotating pier adapter cannot be bolted to a flat surface without an adapter.

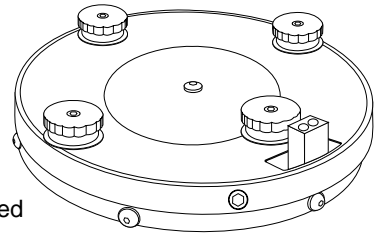

AT YOUR OBSERVING SITE

Assemble Pier (purchased separately)

Begin by assembling the portable pier at the desired observing location. Take note which direction is north.

1. Slide the three legs onto the nubs of the base and rotate the assembly so that one of the legs points toward north (or south, if that is your preference).
2. Place the pier post on the base orienting the center azimuth block directly north. If you choose to have one leg north, then the pier adapter plate will have to be installed with the azimuth block directly over a turnbuckle. If you have one leg south, the pier adapter plate will have to be installed with the azimuth block over and between two of the pier post turnbuckles.
3. Attach the tension rods. The turnbuckles should be drawn tight until the whole assembly is stiff enough to support your weight without movement.

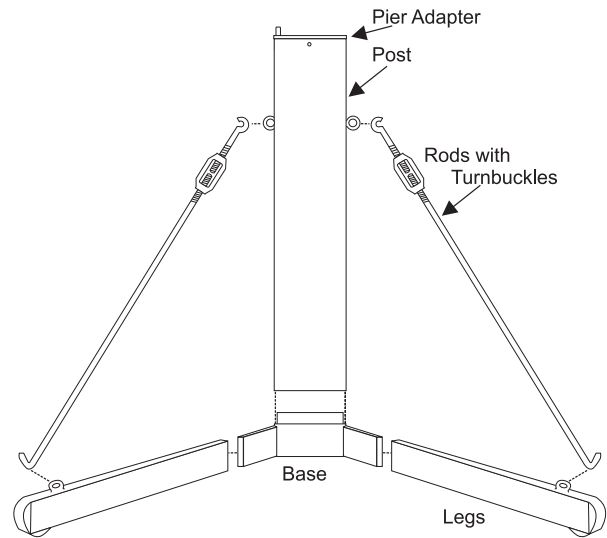

Diagram 6

Assemble Polar Axis Assembly to Pier or Tripod

In order to track the motion of astronomical objects, the polar axis must be positioned so that an imaginary line drawn through the center of the axis points toward the celestial pole. Refer to the diagram at the front of this manual for a graphical representation. At this stage of the assembly process, you want to position the mount so that it points roughly north.

1. Remove the four (4) hand knobs on either the Standard or Rotating Pier Adapter and keep them close at hand.
2. Prior to lifting the polar axis assembly into place, turn the fine azimuth adjustment knobs so that the space between them is wide enough to allow the center azimuth block to fit easily between them. Ensure both pier top and polar axis assembly mating surfaces are clean and free of dirt.
3. Place the polar axis assembly onto the pier top adapter so that the center azimuth block fits between the fine azimuth adjustment knobs.
4. Move the base of the polar axis assembly so that the threaded holes of the pier top can be seen through each of the four slots.
5. Thread the four hand knobs loosely in place (you will tighten these later after polar alignment) with the washers underneath. If you are using the Standard Pier Adapter, be sure that the side with the rounded edge is facing down. This will ensure smooth movements as you adjust your polar alignment. The position of the washers does not matter for the Rotating Pier Adapter.

Polar Alignment

We recommend that you accomplish your polar alignment in two phases – rough alignment and fine alignment.

Rough Polar Alignment

For rough polar alignment, your goal is to sight the celestial pole when looking through the polar alignment sight hole in the center of the polar axis. You will need to make altitude (up/down) and azimuth (side-to-side) adjustments to the position of the mount.

We recommend that you do your rough polar alignment with the R.A. axis only since you will be making major adjustments to the position of the mount at this time. The remainder of the mount, telescope and counterweights would add considerable weight and require more hand effort. Later, you will do your final polar alignment with the telescope and counterweights attached, but the adjustments will be small.

1. Remove the RA axis rear cover (or RA encoder housing if it is installed – please refer to the section of this manual entitled “Installation of Encoders and Encoder Housings – 1200 Mount”). Alternatively, you can simply sight up the side of the polar axis to see Polaris.

2. If you examine the polar axis assembly, you will see that the center of the R.A. shaft is hollow.
NOTE: If you have already attached the Dec. axis, remove the sight hole cover and rotate the internal Dec. shaft by moving the top of the Dec. axis (or the cradle plate if it is attached) to reveal the sight hole that has been drilled into it. Now, you can look through the shaft to the other side.
3. Move the entire pier or tripod east or west until the mount is oriented approximately towards the pole (an imaginary line drawn through the hollow shaft).
4. **Azimuth adjustments:** Use the two fine azimuth adjustment knobs, one on each side of the mount, to make adjustments. You must back off the opposing azimuth knob in order to move the other knob in that direction. Please refer to Diagram 4. Refer to the Azimuth Adjustments section below for information pertaining to the Rotating Pier Adapter and Standard Pier Adapter. The procedures are different depending on which one you are using.

Altitude (latitude) adjustments: Loosen the altitude locking knobs. Move the polar axis up or down with the large altitude adjustment knob located in the front of the polar axis assembly. The tommy bar can be positioned in any of the threaded holes located in the altitude adjustment knob. Use this bar to help you turn the knob. Please refer to Diagrams 3 and 4. We have found that fine altitude adjustments also can be made using the turnbuckle on the north leg of our pier, if used.

One turn of the altitude knob is approximately 0.5 degrees (30 arc minutes).

5. Continue your azimuth and altitude adjustments until you can sight Polaris in the polar alignment sight hole. At this point, you have achieved rough polar alignment, which may be sufficient for casual visual observations if you are not planning to use go-to functions, i.e. slew to target objects with the keypad or planetarium program. When the R.A. motor is engaged, it will compensate for the rotation of the earth and keep the target object within the eyepiece field of view. Your target object will slowly drift since polar alignment at this stage is only approximate. However, you can make corrections with your keypad as we will discuss later.
6. Altitude: Tighten the altitude locking knobs by hand.
7. Azimuth:
 - a) Standard Pier Adapter: Tighten the pier knobs firmly by hand.
 - b) Rotating Pier Adapter: No further tightening required.

Fine Polar Alignment

If you plan to use any of the go-to functions of the 1200GTO or do astrophotography, you must polar align. Procedures will be discussed here, however you will complete this alignment when your scope and other equipment are mounted.

Methods for fine polar alignment

- Polar Alignment Scope – Our optional polar scope (PASILL3 or earlier models) will allow you to quickly align your mount on the pole stars. The reticle was designed for use in both the Northern and Southern hemispheres. Even users of the GTO computerized mounts will find these polar scopes useful, particularly if your telescope is not orthogonal to the mount (please refer to the keypad manual for a discussion of orthogonality). If you have a polar alignment scope, please read the instructions sheets that come with it. If you are planning long exposure astrophotos or imaging, we suggest that you use the polar axis telescope, then tweak the final polar alignment by another means, perhaps CCDOPS from SBIG or other similar alignment program.
- GTO Keypad – Please refer to the instruction manual for the GTO Keypad and read the section describing the startup sequence and various polar alignment procedures including a procedure you can do in the daytime.
- CCDOPS - We suggest that you refer to detailed instructions in the GTO Keypad manual for a method that utilizes CCDOPS from Santa Barbara Instrument Group (SBIG) for precise polar alignment. There are also other similar alignment procedures, including one in MAXIM DL from Diffraction Limited.
- Star Drift method – Traditionally, this has been regarded as the most accurate method of polar alignment. However, if you are using the old method of drift alignment (star near eastern horizon, etc), you are doomed to failure. To obtain more accurate results, choose stars somewhere near the celestial equator due south or slightly east and west, but not below 45 degrees elevation. If you attempt to drift align below that, you will encounter atmospheric refraction, which skews your alignment.
- JMI Digital Setting Circles – Please read the instructions included with your JMI unit. You must have the encoders installed on your 1200 mount (part #1200ENC). Refer to the section of this manual entitled "Installation of Encoders"

and Encoder Housings –1200 Mount. Keep in mind that the encoder resolution of Digital Setting Circles is much coarser. Therefore, this is the least accurate method.

- Members of the ap-gto Yahoo group occasionally discuss alternative methods of polar alignment that they have found helpful. We suggest that you participate in this Internet discussion group. Follow the links from the sidebar of our website to find the group.

Azimuth Adjustments

The one-piece Azimuth Adjustment assembly makes for easy and accurate polar alignment in your observatory or in the field. The heavy-duty construction and integrated one-piece design results in smooth control of the azimuth axis. Large left and right adjuster knobs are graduated for precise control of azimuth position angle. ***The small graduations are 1.3 arc minutes per graduation; long graduations are 6.5 arc minutes per graduation.*** The size of the knobs makes them easy to turn with very little torque required, even with the mount fully loaded.

The procedure for making azimuth adjustments is somewhat different with the Rotating Pier Adapter (1200RPA) and Standard Pier Adapter (1200SPA). If you are using your own pier adapter or one provided with the Particle Wave Technologies Monolith Pier, there may be additional considerations to achieve smooth, accurate adjustments.

Rotating Pier Adapter with Azimuth Bearing (1200RPA)

The rotating pier adapter consists of two plates that allow ultra-smooth adjustments for critical polar alignment. When using the Rotating Pier Adapter, tighten the hand knobs fully by hand. It is not necessary to use a wrench. These will remain tight during and after the adjustment procedure.

Notice the two setscrews on the side of the rotating pier adapter. These setscrews are used to apply tension to the rotating plate. You may need to adjust these setscrews to gain the proper feel during the adjustment process. If you notice a slight amount of shift, particularly with a larger scope, tighten the screws. If you find too much resistance, the screws may need to be loosened slightly.

Azimuth adjustment is accomplished with the two fine azimuth adjustment knobs, one on each side of the mount. You must back off the opposing azimuth knob in order to move the other knob in that direction. Please refer to Diagram 4. Follow one of the alignment methods discussed above in the Polar Alignment section.

Once your azimuth position has been attained, do not tighten the hand knobs any further since this is likely to disturb your alignment.

Standard Pier Adapter (1200SPA)

Each of the azimuth lockdown knobs has a hardened washer. With these washers, the lockdown knobs can hold the mount down tight while still allowing the axis to be easily adjusted with your fingers. These will eliminate minor shifts in the axis when you are tweaking your azimuth adjustment.

The washers have a sharp-edged side and a rounded-edge side (the difference is subtle). Place them with the sharp edge of the washers facing up toward the knob, rounded edge down onto the painted surface of the base plate. If you install the washers with the sharp edge down, they will bind into the paint and prevent smooth movement. If you do not have a permanent installation, you may wish to mark the down (or up) side of the washer with a marker so that you can quickly identify the desired orientation. If you have a rotating pier plate, the orientation of the washers is not important at all.

1. The altitude axis should be fully locked down with a hex key before adjusting the azimuth.
2. Follow one of the methods of polar alignment mentioned above.
3. During the initial adjustment phase, the 4 lock-down knobs should be hand tight only. This will allow easy movement of the azimuth axis.
4. When you are close to the final position of the azimuth axis, use a hex key to lock down the rear knob only. The azimuth can still be moved with the adjusters, but it will now be solidly connected to the pier top. The other knobs should remain hand-tight. The weight of the mount and scope puts pressure on the front of the plate for a solid connection, so it is not necessary to lock them down fully with a hex key.

Altitude Adjustment

Loosen the altitude locking knobs. Move the polar axis up or down with the large altitude adjustment knob located in the front of the polar axis assembly. The tommy bar can be positioned in any of the threaded holes located in the altitude adjustment knob. Use this bar to help you turn the knob. Please refer to Diagrams 3 and 4 if you are unsure about these parts. It is also possible to make fine altitude adjustments by using the turnbuckle on the north leg of our pier, if used.

One turn of the altitude knob is approximately 0.5 degrees (30 arc minutes).

Tips for Adjusting the Altitude

The mount's polar axis is held in place between the two side plates. It is possible for the mount to shift slightly when the side bolts are fully tightened down after adjustment of the altitude angle. To prevent that, it is suggested that the initial altitude adjustment be done with these bolts hand tight, and as you approach the final adjustment point, tighten the bolts with a hex key after each movement. If you move the axis too high and overshoot the angle, it is better to loosen the two bolts a bit, bring the axis back down a very small amount and progress back up with the bolts hand tight. This way you are using the weight of the mount to insure a solid connection to the altitude adjuster. During the final adjustment phase, screw the Tommy bar into one of the holes in the knob. This bar can then be used as fine adjustment tool and is a good indication of the position of the axis.

Assemble Declination Axis

1. Do not have your telescope or counterweights connected to the Dec. axis assembly for either assembly or disassembly of the Dec. and RA axes.
2. Position the R.A. axis as shown in Diagram 7 with the pocket "A" at the top, opposite the altitude adjuster knob. Firmly tighten R.A. clutch knobs.
3. During shipment, the Dec. axis assembly lock knobs will be fully screwed into the Dec. axis. For correct assembly, these lock knobs should be unscrewed at least 7 full turns and no more than 8.5 full turns. This is between 5/16" and 3/8" out from the "shipped" tightened position.
Note: These lock knobs can be completely removed from the Dec. axis assembly with about 9.5 full turns out.
4. Position the Dec. axis above the R.A. axis as shown in Diagram 8, a light movement (wobble) in the downward direction (arrow "A") will help to correctly seat the principle dovetail(s) and parallel guides.
5. When both Dec. and R.A. assemblies are fully seated, hand tighten both Dec. lock knobs.
6. Thread the counterweight shaft into the Dec. axis.
7. Remove the hand knob and safety washer from the base of the counterweight shaft. Add sufficient counterweights (10 or 18 lb. counterweights are purchased separately) to the declination shaft to balance the telescope you intend to use. Always use two hands to attach or move them on the shaft.
8. Reattach the hand knob and safety washer to the end of the declination shaft. This will help to prevent injury if someone accidentally loosens the counterweight knob.

NOTE: Firm tightening of the counterweight knob will not damage the surface of the counterweight shaft. The pin that tightens against the stainless counterweight shaft is constructed of brass. Likewise the bronze sleeve that has been press fit into the center of the counterweight will prevent marring of the shaft as you move the counterweight up and down.

Removing Declination Axis at the End of your Observing Session

1. Unscrew the lock knobs 5.5 to 7 full turns (this is still 5/16" to 3/8" out from the fully tightened position) and slide/tilt the Dec. axis assembly in an upwards direction (arrow "B").
2. For transport/storage we recommend fully tightening the lock knobs.

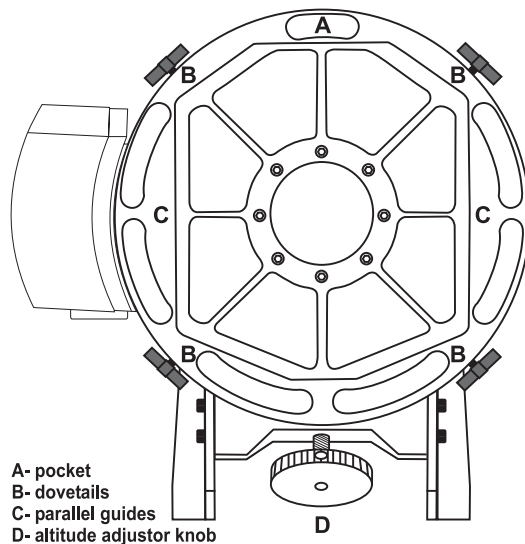

Diagram 7

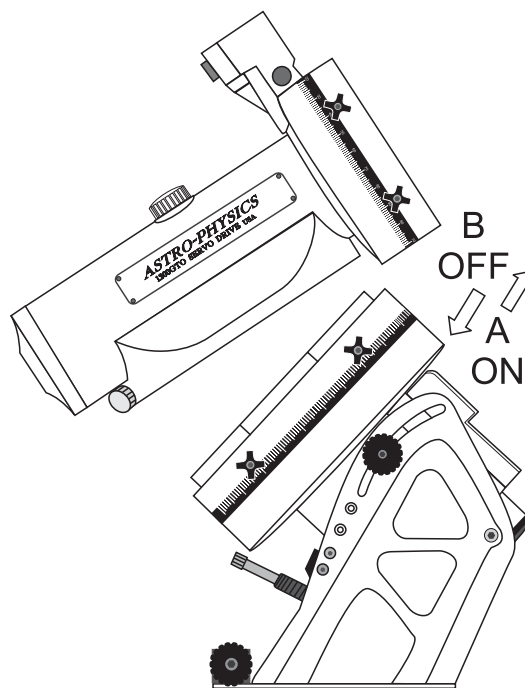

Diagram 8

Attach Mounting Plate (purchased separately)

Several mounting plates (also called cradle plates) are available for the 1200 mount. If you own more than one instrument, you may need more than one plate. Follow the appropriate directions for the plate(s) that you have. The darkened holes represent those used for the 1200 mount.

18" FLAT MOUNTING PLATE (FP1800)

This plate is 18" long and 7.5" at its widest point in the center. The width of the plate tapers to 5.5" at each end. Four pairs of keyhole slots that measure 3.2" between centers are provided. The two inner pairs are 13.75" apart and the outer two pairs are 17" apart. You can drill additional holes to suit your needs. This plate also fits the 900 German Equatorial. Attach this plate with six 1/4-20 x 1" flat head socket cap screws

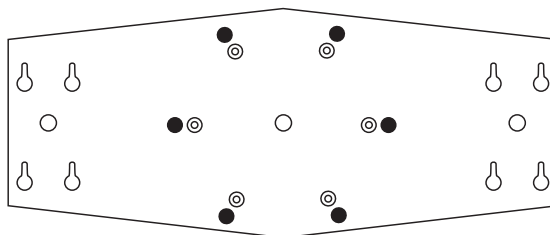

Diagram 9

15" RIBBED MOUNTING PLATE (1200RP15)

This plate is 14.75" long, 7.75" at its widest point 5" at each end and 1" thick. The underside of the plate is carved into a ribbed pattern to maximize the strength and minimize the weight - 3 lbs. A pair of keyhole slots that measure 3.2" between centers are provided at each end. The distance between the pairs is 13.75".

Attach this plate with six 1/4-20 x 3/4" socket head cap screws
Note that the plate is asymmetrical. In most cases, orient the plate so that the long end points toward the sky. You can also turn the plate in the other direction to balance your scope.

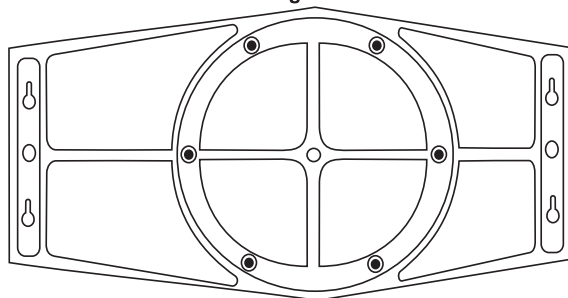

Diagram 10

24" RIBBED MOUNTING PLATE (1200RP)

For larger instruments, the ribbed structure of this plate provides the maximum support. Our machinist begins with thick aluminum plate and carves a strong rib structure. The final result is 1.5" thick, 24" long and 7.6" at its widest point. The width of the plate tapers to 5.5" at each end. A pair of keyhole slots that measure 3.2" between centers are provided at each end. The distance between these pairs of holes is 23". Due to the ribbed structure, you may not be able to drill additional holes for non-Astro-Physics mounting rings. The plate weighs an amazing 9.5 lbs. for its size. This is a view of the rib structure on the underside of the 24" plate.

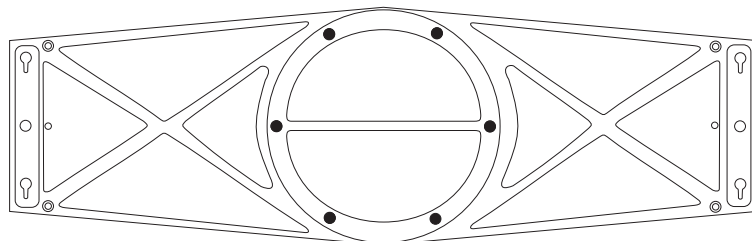

Diagram 11

Attach this plate with six 1/4-20 x 1" socket head cap screws.

8.5" DOVETAIL FOR LOSMANDY D SERIES PLATE (DOVELM2)

This Astro-Physics plate attaches to the 400, 600E, 900 and 1200 mounts. If you already own one of the Losmandy DAP series (fits Astro-Physics refractors), DC series (for Celestron 8", 11" or 14" SCTs) or DM series (for Meade 8", 10" and 12" SCTs) plates, this is the mounting plate for you.

Note that the bolt-hole pattern is offset from the center. This allows you to position the plate either forward or backward depending on the balance point of your telescope. Attach this plate with four 1/4-20 x 3/4" socket head cap screws and two 1/4-20x5/8" flat head socket screws.

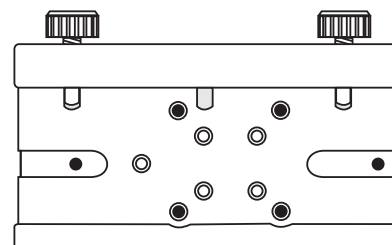

Diagram 12

16" DOVETAIL FOR 1200 MOUNTS AND LOSMANDY D SERIES PLATES (DOVELM16)

This Astro-Physics plate attaches to the 1200 mount. If you already own one of the 17.25" or longer Losmandy DAP series (fits 6" and larger Astro-Physics refractors), DC series (for Celestron 11" or 14" SCTs) or DM series (for Meade 10", 12" and 14" SCTs) plates, this is the mounting plate for you.

Note that the bolt-hole pattern is offset from the center. This allows you to position the plate either forward or backward depending on the balance point of your telescope. Attach this plate with seven 1/4-20 x 1" socket head cap screws.

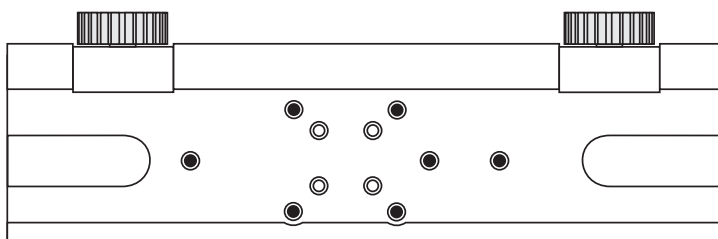

Diagram 13

Understanding the R.A. and Dec. Clutch Knobs

We suggest that you read this before assembling the remainder of your system.

1. What do they do?

The four R.A. and four Dec. clutch knobs depicted in Diagram 2 have the function of connecting the R.A. and Dec. axes to their respective drive worm wheel gears. Their function is progressive, from no tension (axes free to move - as required during correct balancing of the telescope) to a completely "locked up" state.

2. How can you find out what they really do?

As shipped, all 1200 mounts have all four R.A. and Dec. clutch knobs firmly hand tightened. This will give you a good idea of the maximum tightness (clutch action) that can be achieved by hand effort alone. At this point, you must bear in mind that for optimum performance all four clutch knobs on each axis (R.A. or Dec.) should be tightened evenly with the same tension i.e. all four half tight, all four fully tight, etc.

In order to feel the effect of the clutch knobs, you may wish to partially assemble your mount. Fit together the R.A. and Dec. assemblies plus mounting plate and counterweight shaft. Do not put scope and counterweights on at this stage. With the above assembly (with the clutch knobs firmly hand tightened - "as shipped"), you can feel the amount of force needed to move each axis by hand. Grab each end of the telescope mounting plate and move it with a backward and forward movement of the Dec. axis. You will feel considerable resistance to this motion. Perform the same operation on the R.A. axis by moving the counterweight shaft backward and forward. With a well-balanced telescope, the above tightness of the clutch knobs will be sufficient for all normal conditions of use.

Now, if you proceed to mount up and balance your telescope, you can "feel" what this resistance in R.A. and Dec. (movement backwards and forwards) is like when you make these motions from the eyepiece end of your telescope as you would during normal use when slewing (pushing) by hand to acquire an astronomical object within the field of view of your finder or scope.

3. How tight can the clutch be and can you do any damage by pushing against them?

The maximum tightness of this clutch system is 1/3 turn (with a 5/32 allen key) further in than the tension you can achieve with the knobs by hand. You will see that each clutch knob has a 5/32 hex socket for tightening with an allen key. With this extra 1/3 turn on each clutch knob, the axis (axes) will be considered completely "locked up" and you should not attempt to push your scope by hand against this "locked up" resistance, or undue stress will be placed on the worm wheel/worm and bearings.

However, if you are undertaking a very long astrophoto exposure, it is advisable to increase the pressure on each clutch knob (with the 5/32 key) by about 1/8 turn on Dec. and 1/8th turn on R.A. You may safely slew the scope by hand with this tension, however you will notice considerably more effort is required to achieve movement. This is the absolute maximum tension that can be used for hand slewing. As a general rule, if you have a big scope (7" or 8" refractor) with all the accessories, you will need more clutch tension than a 5" or 6" scope.

Resist the urge to overtighten the clutch knobs with the hex wrench. This will only cause them to deform and lock into position. If you find that you are no longer able to adjust the tension and the knobs are locked firmly in place so that the axis will not move, contact Astro-Physics for technical assistance.

Attach Counterweight Shaft and Counterweights

IMPORTANT:

- Always attach the counterweights before mounting the telescope to the cradle plate to prevent sudden movement of an unbalanced tube assembly, which may cause damage or injury.
 - Remember counterweights are heavy and will hurt if they fall on your foot.
1. Thread counterweight shaft onto the Dec. axis.
 2. Remove the hand knob and washer from the end of the counterweight shaft. Add sufficient counterweights (10 or 18 lb. counterweights are available) to the shaft to balance the telescope you intend to use. Loosen the counterweight knob and hold the counterweight with the knob pointing downward so that the brass pin will move from the center opening allowing the counterweight to slide into position. Always use two hands to attach or move them on the shaft.
 3. Reattach the hand knob and washer to the end of the counterweight shaft. This will help to prevent injury if someone accidentally loosens the counterweight knob.

A firm tightening of the counterweight knob will not damage the surface of the counterweight shaft. The pin that tightens against the stainless counterweight shaft is constructed of brass. Likewise, the bronze sleeve that has been press fit into the center of the counterweight will prevent marring of the shaft as you move the counterweights.

Attach Mounting Rings and Scope (purchased separately)

Flat and ribbed plates: Our flat and ribbed plates are constructed with keyhole slots at the location where your mounting rings attach. This feature enables you to partially loosen the screws on your rings just enough to insert them into the larger part of the keyhole, then slide the rings to the narrow part and tighten them with a hex key. We prefer this keyhole method to the standard way of completely removing the screws and dropping them in the grass.

We suggest that you install the rings on the mounting plate, then open the rings, lift the scope in place, close the rings and tightened the knobs. To balance the scope, you can loosen the knobs enough to slide the scope forward or backward as needed.

Another approach is to attach the rings to the scope beforehand, then lift onto the mounting plate. However, the rings must be spaced exactly the correct distance apart to match the holes in the plate. This maneuver may be particularly difficult to accomplish with a large, heavy instrument.

Dovetail plates or sliding bars: Attach mounting rings to the male dovetail plate matching the appropriate threaded holes on the bottom of the mounting ring. Again, you have the option of attaching this dovetail/ring assembly to the mount and lifting your scope in or placing the scope in the rings, then lifting the entire assembly to the female mounting plate already attached to the mount.

Balancing Your Telescope

For proper operation, the telescope must be adequately counterbalanced. Start by balancing the tube assembly.

1. Tighten the 4 R.A. axis clutch knobs.
2. Loosen the 4 Dec. axis clutch knobs (about 3/4 to 1 turn) so that the telescope moves freely about the declination axis (be careful because if your telescope is significantly out of balance, it may swing rapidly in the out-of-balance direction!)
3. Position the R.A. axis so that the counterweights are in their "lowest" position i.e. the declination axis assembly is in the meridian (this is the usual way that German equatorials are depicted, as shown in diagram 2.)
4. Loosen the tube mounting rings and slide the tube up and down for balancing. This is best done with the tube in the horizontal position. If you are using a dovetail mounting plate, loosen the hand knobs and slide the mating plate to the desired position.
5. The scope is balanced when it stays put (does not move) with the clutches loose and movement back and forth about the declination axis has the same feel in both directions.
6. Now, tighten the declination axis clutch knobs and position the telescope horizontal and the declination axis horizontal. The center of the counterweights is now the same height as the middle of the tube.
7. Loosen the R.A. clutch knobs. Again, be careful, because if your scope is significantly out of balance, it may swing rapidly in the out of balance direction).
8. Move the counterweight(s) up or down to achieve the correct balance in R.A. Movement back and forth about the R.A. axis should have the same feel in both directions.

Try to anticipate any balance problems due to the extra weight of diagonals, heavy eyepieces, finders, solar filters, etc. If the scope moves by itself, when the clutches are loose, then the scope is not counterbalanced adequately. If you are doing astrophotography or imaging, a small amount of imbalance (more weight on the east side of the mount) is permissible and indeed desirable.

Fine Polar Alignment

Now is the time to complete your final polar alignment. Please refer to the previous section for details.

SERVO MOTOR DRIVE

GTO Control Box – Model GTOCP3

The GTO control box contains all of the circuitry to drive the two servo motors and the logic required to navigate the sky. It will be operational and track at the sidereal rate when connected to both motors of the mount and a power source. In order to control the movement of the mount, you will need to connect at least one of these:

- GTO Keypad.
- PulseGuide by Sirius Imaging. The CD for this program is included with the mount. For the most updated version of the software, check out the website www.pulseguide.com. Please refer to the section later in this manual for further information regarding the capabilities of this program.
- Computer with astronomical software such as *DigitalSky Voice* or planetarium programs such as Software Bisque's *TheSky™*, Nova Astronomics' *The Earth-Centered Universe (ECU)* version 3.1 or later, and Chris Marriot's *Sky Map Pro 6* or any ASCOM compatible telescope software (all purchased separately).

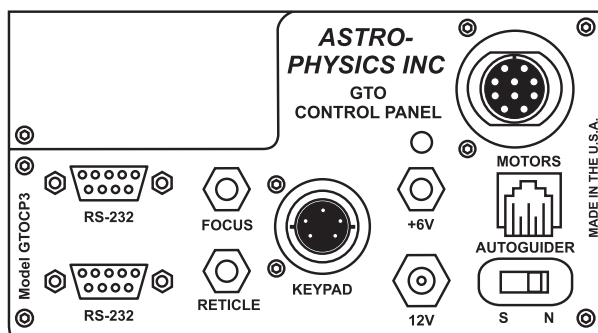

Diagram 14

The GTO Servo Control Box is mounted directly onto the polar axes of the 1200 mount. Please remember that this box contains advanced electronics and must be treated with the same care given to other fine equipment. You can see that the unit is built to be rugged, however it is not indestructible.

R.A. and Dec. Cable Connections

A “Y” cable with 10-pin connectors is included with your mount. Attach the connector from which the two cables emerge to the GTO Control Panel. Attach the short part of the “Y” cable to the R.A. motor housing and the long part of the cable to the Dec motor housing. Lock all connectors. Refer to the section below for further information about positioning the cables.

12V Connector

Place the DC power cord (included with your mount) into the phono plug outlet marked 12V on the GTO Control Panel and lock in place. Plug the cigarette lighter plug end of the cord into your power source. The acceptable voltage range is 11.5 to 16. Suggested power sources include: portable rechargeable battery pack, auto or marine battery, or power supply (filtered and regulated) for 110 volts with a minimum output of 5 amps at 12V DC.

There is no on-off switch. We recommend that you plug the power cable into the servo box after the keypad controller. To turn the unit off, simply disconnect the power cable.

Considerations for observatory installations: We suggest that you disconnect your GTO Control Box from 110V and any other device (CCD camera, computer, etc) when you are not using your mount so that if your observatory experiences a power surge or lightning strike, your mount electronics will not be damaged. If you operate your mount remotely, you will have to leave your power cable connected just as you do for the rest of your electronic equipment. You may want to consider surge protectors or other protective measures to protect from voltage spikes. A disconnect relay to remove power from both the 12-volt and ground wire is highly recommended in this situation.

POWER Indicator Light

This LED will remain illuminated when your power source has sufficient output to drive the motors. If the voltage falls below 10.5 volts, the power light will go out and the motors will stop. The keypad will not function properly.

For mounts shipped after 02-25-00: If the LED turns yellow, this means that your motors are overloaded, probably due to an unbalanced load on your mount. Refer to the troubleshooting section of the manual for the solution. Earlier control boxes do not have this feature.

KEYPAD Connector

Attach the 5-pin male connector of the keypad controller and lock in place (push in the knurled ring then turn).

RS-232 Connectors

These serial port connections are used to connect your mount to your PC computer. You must provide your own straight-through (non-crossing) cables with a 9-pin (DB9) male connector to interface with the GTO panel. We have provided the locking posts to secure the cable firmly. If your serial cable does not have a 9-pin connector, you can use a gender changer or adapter to convert it. If your computer has USB ports, use a quality adapter to gain a serial port.

When you are controlling the position of the mount with a computer program such as *DigitalSky Voice™* or Software Bisque's *TheSky™*, the microprocessor chip located in the servo drive box will send continual RA and Dec coordinate data via the cable connections to your computer. When you use the software to give instructions to slew to a new object, the commands (RA and Dec coordinates) are sent to the mount.

We provide two serial port connections on the mount so that you can use two software programs simultaneously. For instance, you can use PulseGuide for advanced mount control, while using *TheSky* as a planetarium program. The telescope control functions of *TheSky* are more limited so using both in a remote application is advantageous. Since the mount will update the RA and Dec coordinates simultaneously, both programs are continually updated with the data from the mount. You can watch the screen display of *TheSky* to see where your telescope is pointing as it slews. This is most effective if you have a reasonably fast computer with plenty of RAM. If you try this with a 100MHz processor and only 32 MB of RAM, the response time will be slow since both programs must be continuously updated with position data.

You must have two serial ports available on your computer to take advantage of this feature. If you use a laptop, you may need to purchase a PCMCIA adapter to gain an additional serial port. Socket Communications offers adapters for many computers. Check out their web site at www.socketcom.com.

FOCUS Connector

Attach the 3.5mm phono plug connector of your JMI Motofocus or other electric focuser (optional accessories) here. Refer to the section regarding focus adjustment in the GTO Keypad Manual for instructions on using the keypad controller to adjust focus. Alternatively, you can verbally control the focus using the Focus Mode of *DigitalSky Voice* software.

RETICLE Connector

If you wish to use the illuminator cable for our Polar Alignment Scope (PASILL3), a plug-in type guiding eyepiece with an illuminated reticle (available from several manufacturers), insert the 3.5mm phono plug into this connector for power. Reticle brightness can be adjusted with the keypad. Refer to the section pertaining to reticle illuminator adjustment in the GTO Keypad Manual for further information.

AUTOGUIDER Connector

This connector interfaces with the RJ-11-6 modular jack of an autoguider cable, purchased separately or as part of a CCD Imaging Camera or Autoguider. The autoguider will be functional and ready to go as soon as you plug it in. Please refer to the appropriate manual from the manufacturer for operation of the autoguider.

We offer cables for all SBIG cameras. Please refer to our price list or call for further information.

+6V Connector

This 6-volt output accepts 3.5mm phono plugs. It is used primarily to power the Pentax 6x7 camera directly from the mount with a cord sold for that purpose (our part # CORD01).

N and S Switch

Select northern (N) or southern (S) hemisphere as needed. When you slide the switch to the opposite position, the tracking direction of the drive will reverse. The power cord must be removed and re-attached to make this work.

Removing the GTO Control Box From 1200 Mount



The GTO control box can be removed easily from the RA axis. It is secured by two 8-32 set screws located at the base of the GTO Servo Control Box. Loosen the screws with one of the hex keys from the set included with the mount. Lift the box up from the bottom and tilt so that it frees from the dovetail connection.

Some people have a permanent observatory, yet prefer to store their electronics in their home to keep them clean and free of cobwebs. If you do, you may wish to substitute the 8-32 thumbscrews (included with your mount and shown in photo) for the setscrews. This will allow you to remove and install your GTO control box without tools.

GTO KEYPAD OPERATION

Please refer to the manual for the GTO Keypad Controller for complete instructions.

PULSEGUIDE BY SIRIUS-IMAGING

See www.pulseguide.com for the latest information.

CABLE MANAGEMENT

The movement of the mount across the meridian during slewing functions is calculated so that the cables will not tangle if they are set up properly. In addition to the motor and power cables that are provided with the mount, you may have additional cables for other accessories. These may be powered from the GTO Control Panel or from another power source. We suggest that you position your cabling carefully to avoid a tangled mess. When your cables are set up, move the telescope manually throughout the normal range of movement to be sure that the cables do not catch on anything and that you have enough length. Here are a few pointers:



1200 Motor Cables

Note that the “Y” cable for the 1200 mount originates at the GTO Control Panel connector, then splits into two. The short portion connects to the RA motor box and is not likely to be in the way because this axis remains in the same position. We have provided a cable mount to position the Dec cable neatly. The longer Dec portion of the cable must be set up properly to ensure that as the Dec axis moves, the cable follows smoothly. Please insert this cable into the cable mount in the upper left corner of the GTO Servo Control Box as shown above. When the connector is attached to the Dec motor box, the cable should be positioned as shown in the photograph.

Accessory Cables

Accessories may include Kendrick Dew Removers, CCD cameras and autoguiders, focus motors, illuminated guiding eyepiece reticles, power cords for the Pentax 6x7 camera, etc. As you attach each accessory, carefully assess the best position to assure complete movement as your telescope slews from one side of the mount to the other. If an external power source is used, determine the optimum location for the battery. We prefer to use tie wraps (not glamorous, but effective) or cable ties (from electronic supply store or catalog) to secure our cables to the mount, telescope, rings or bind them together. Adhesive cable mounts similar to the one that we use for the Dec. cable are an alternative choice. We prefer to use ties since we cannot bear to attach adhesive cable mounts to our telescopes or mounts.

Example from International Space Station – Amateur Telescope (ISS-AT) Project



If we use tie wraps to secure several cables together and plan to use that same setup in our next observing session, we keep the ties in place when we disassemble our equipment. The setup for the next session is much quicker.

The photo on the left shows how the cables were arranged on the 1200GTO that was installed at a permanent observatory for the International Space Station – Amateur Telescope (ISS-AT) project of the Astronomical League. This mount is operated remotely and cable management is essential. The scope is a modified Celestron C-14 and the accessories included: CCD camera, color filter wheel, remote focuser and Kendrick Dew Remover.

Note how the wire bundle is attached to the mounting plate before looping back to the pier. Attaching the wires securely to the plate prevents any kind of motion or disturbances to the camera during

image acquisition and guiding. The loop is made long enough to allow the scope to reach all portions of the sky with plenty to spare. The people who installed system ran the scope all over and reported zero interference.



This photo shows the mount and scope with the wire loop containing all the cables from the CCD camera, color filter wheel, remote focuser and Kendrick Dew Remover. If you look closely, you will notice that the two clutch knobs were removed and replaced with special Allen head bolts. This allowed the Dec cable to slide easily over the axis in all orientations and there was no snagging of the wire anywhere. Please call Astro-Physics if you would like to order these bolts. Do not try to install normal Allen head bolts

For a portable setup, we keep the ties wraps in place as much as possible when we disassemble our equipment. The setup for the next session is much quicker.

SLEWING YOUR MOUNT IN BELOW FREEZING TEMPERATURES

Notes from Roland during a very cold spell in January 2005:

“There are several potential problems when slewing your mount in below freezing temperatures. The symptoms are a wavering or chattering sound from the motors, a slowing down of the slewing with a sudden jolting stop at the end of the slew, and in the worst case, a continuous running of the motors and loss of control. I have seen similar things on my own mounts when the temperature dips below zero F. There are three things that you can look at to alleviate the problem.

First, in cold weather it takes a very much larger amount of power to slew the motors than it does in the summer (see tests I ran below). This extra current drain can cause a voltage drop in the power cord running from the supply to the servo. If you have a long distance between the supply and servo, use a heavy wire to minimize the voltage drop. If the power drops below about 11 volts at the servo terminal, the internal computer chips may reset with subsequent loss of control of the motors. If your supply is marginal, it may also not produce the voltage necessary for proper operation during slews. It is a good idea to limit the slew speed to 600x during real cold weather to reduce the power demand from the supply.

Second, it is very important to have the worm mesh not set overly tight. One symptom of overly tight worm is a chattering sound as the motors try to slew at 1200x or even as low as 600x. You can check to see if the worm turns easily with your finger by removing the motor covers and removing the large spur gear to get access to the worm end. Try turning it by hand. If it does not easily turn, then the motor will also have a difficult time turning it. Check in our technical section of the AP web site on how to set the worm mesh. In real cold weather, well below zero F, it might also be a good idea to lubricate each of the spur gears and their sleeve bearings with a light machine oil. When warmer weather returns, this can be replaced with a light grease, Lubriplate 105, which will reduce the wear factor in warm temperatures.

Third, under very extreme temperature conditions below -20F, it may be necessary to replace the grease on the worm wheel teeth with a lighter material. The mounts use a special formulation of Lubriplate 105 with a damping grease added. This combination is ideal for low wear since the damping grease portion allows the grease to stay on the teeth and not get wiped off by the motion of the worm. Although this combination works well even at temperatures below zero, it does get more viscous in really cold conditions. We have tried straight low temperature greases that work to -80F, and in each case, the worm gears get abraded very quickly. Using no grease at all is also not recommended for a GoTo system that slews at high speeds. The wear on the worm and wheel teeth is extremely high and can develop very high periodic error after a short time due to scratches and high spots that develop on the gear teeth. At this time we have no solution to ultra-low temperatures.

Last night it was -8 F here, and I tested several of our mounts in the observatory. Two are very old, from the original batch, and one is brand new. All worked well at 600x but showed signs of laboring at 1200x slewing. I use a 12-volt marine battery to power them. I replaced the marine battery with a variable power supply that I varied from 12 volts to 18 volts. At 12 volts when both motors were slewing at 1200x, the power draw was in excess of 8 amps (in summer this is around 2.5 amps). The motors were laboring and not running smoothly at full speed. I turned up the voltage to 15 volts, and the current draw dropped to around 5-6 amps. The motors worked smoothly at 1200x with no hesitation at that voltage level. I would recommend for cold weather work to get a supply that can deliver 15 - 16 volts at a rated current capacity of 10 amps. Higher than that is not necessary. Above 18 volts is not recommended.”

MOUNT CARE AND ALIGNMENT

Your 1200GTO is a precision instrument with very accurate worm and wheel adjustments. Please be careful if you place the mount on a flat surface, i.e. the ground or trunk of your car. The gear alignment may be affected if the R.A. and Dec. motor/gear box assemblies sustain undue lateral force. This is true of any fine instrument. We suggest that you transport and store the mount in a case or in a well-padded box.

Mount Maintenance

Under normal operating conditions, minimal maintenance is required. Every 12 months the clutch knobs (4 for Dec. and 4 for R.A.) should be removed and 1 or 2 drops of light oil (3 in 1 household oil) should be put in the exposed hole. If the R.A. and Dec. axes are attached together for a long time in outside conditions (i.e. in a permanent observatory) then the mating surfaces should be lightly oiled or greased - if you expect to get them apart again after 10 years.

Tips and support

For additional information regarding the 1200GTO, refer to the Technical Support Section of our website. We also encourage you to participate in the ap-gto user group. The members of this group are very knowledgeable about the operation of their mounts, CCD imaging and other related issues. The staff of Astro-Physics also participates and you will find a wealth of information in the archives. To find the group, link from User Groups in the sidebar of our website.

We encourage you to submit your technical support questions directly to Astro-Physics by phone or e-mail: support@astro-physics.com.

TROUBLESHOOTING

The troubleshooting issues below relate to the mechanical or electrical function of the mount. Additional troubleshooting questions are in the GTO Keypad manual. Please refer to them.

The declination (or RA) axis is fairly tight even with the declination clutch knobs fully loosened.

Under each clutch knob is a Delrin plug with a tiny hole in it. This plug acts as the clutch material and when pressure is applied via the knob, it presses against the worm wheel hub to couple the Dec axis to the underlying worm wheel (so it can turn when the worm turns). When these clutch knobs are pressed too tight for long periods of time, the Delrin plugs tend to splay outward and expand into the sides of the threaded hole. Then, they will not retract when you loosen the clutch knob pressure, and what you have is sort of a permanent friction of the Delrin material against the worm hub.

It is quite easy to fix this. Simply remove the clutch knobs, then remove the Delrin plugs. If you have a 4-40 tap handy, you can try to thread it into the hole in the middle of the clutch plug. Then, simply pull it out with the tap. Alternatively, you can borrow or purchase a modified screw driver from Astro-Physics to remove the plugs.

Once out of the hole, you can either sand the outside down with a bit of emery paper until it goes smoothly into the threaded hole in the Dec axis, or call Astro-Physics, and we can send you 4 new ones (or 8, if both axes are involved). Replacement with new ones is the preferred solution, however sanding them down may get you up and running quickly.

Remember that the clutch plugs do not have to be tightened heavily with a hex key in order to be effective. Over tightening will cause this problem. If replacing the clutch plugs does not resolve your problem, please call Astro-Physics for assistance.

The LED on the GTO Control Box changes from red to yellow and the motors stop or go out completely (for mounts shipped after 02-25-00).

1. The motors are overloaded, probably due to an unbalanced load on your mount.

Rebalance your telescope, and then press one of the N-S-E-W buttons to reset the keypad. Re-enter the last object on your keypad and the scope will slew to the correct position. Even though your motors had stopped, the logic in the control box retained the scope position in memory. As long as you didn't change the pointing position of the scope, you are still calibrated.

If the scope was moved during re-balancing, simply enter a nearby bright star on the hand controller, press GOTO and allow the mount to finish slewing. You can then move the scope manually or with the N-S-E-W buttons to center the star in the eyepiece, and press the #9 RECAL button. This will recalibrate the mount.

Additional explanation: The GTO drive circuit includes logic for overload protection to prevent burning out the

expensive servomotors in case of severe overload on the two axes. The primary cause is an unbalanced load in R.A. If the extra load opposes the motor rotation, the motor must work harder to track at the sidereal rate and the current will rise to high levels. If the current exceeds the trip point for more than a minute, the logic will shut the motor off and tracking stops. It typically takes about 4 lb. of unbalance to trip the overload, but a very heavy load of scopes, accessories and counterweights on the mount can decrease this unbalance threshold.

2. The voltage of your battery has probably gone below 10.5 volts.
3. The current rating of your AC-DC power supply is too low.

Additional explanation: During slewing, the two motors draw up to 3 amps from a 12 volt source. This may increase when the temperature approaches freezing or below. It is recommended that your supply be rated at 5 amps, 12 volts DC minimum (18 volts max.). If you also power other equipment (CCD cameras, dew heaters, etc.) from the same source, you will need a supply capable of up to 10 amps. The more equipment you have, the more current capability you will need. For portable applications, we recommend a heavy-duty marine battery designed for deep discharge applications or multiple batteries. The most common problems are due to inadequate power supply.

The keypad reset (or locked up) when I plugged my CCD camera, PC (or other equipment) into the same battery as the GTO mount was using. The battery has a meter, which shows 12V.

The meter is reading an average and will not show dips. Gel cells have internal resistance, which will cause voltage drop when the load changes. When you connect an additional CCD camera and PC the load will drop below 9 volts and the keypad will reset or it may affect the GTO circuit itself and cause the keypad to lock up.

We recommend that you use a large marine battery that is not a gel cell and hook everything up to it before starting up the GTO. Or, better yet, put the dew heaters on a separate battery.

The motors sound louder and more labored in cold weather.

As the temperature drops, we recommend that you reduce your slewing speed to 600x. The cold causes the lubricants to get stiff in the gearboxes. This can make the high-speed gears resonate and sound screechy. Lowering the slew speed in winter will eliminate this. You might also want to add a drop or two of light machine oil to the center posts of the individual gears. Just remove the cover on the gearbox and add the oil drops. The noise is nothing to worry about. Refer the section of this manual entitled: Slewing Your Mount in Below Freezing Temperatures.

If any problems occur, please don't hesitate to contact Astro-Physics for assistance.

ASTRO-PHYSICS INC
11250 Forest Hills Road
Rockford, IL 61115
Telephone: (815)-282-1513
Fax: (815)-282-9847
www.astro-physics.com
support@astro-physics.com

Recommended Reading from our Staff:

The Backyard Astronomer's Guide, Terence Dickinson and Alan Dyer, Camden House Publishing, 1991
The authors, both former editors of *Astronomy* magazine, offer practical insight into astronomical equipment, finding your way around the sky, polar alignment, using setting circles, and astrophotography. This book provides excellent explanations and is well organized and illustrated.

All About Telescopes, Sam Brown, Edmund Scientific Company, 1975. Excellent information regarding the principles of mount construction and operation, using setting circles, eyepiece projection, etc. Illustrations and formulas galore. Many of the instruments pictured are outdated, however the underlying principles are timeless.

Norton's 2000.0 Star Atlas and Reference Handbook, edited by Ian Ridpath, J. Wiley Publishers, 1989.
Star maps, information regarding polar alignment of German equatorials and observing techniques.

INSTALLATION OF ENCODERS AND ENCODER HOUSINGS -1200 MOUNT

1200ENC (purchased separately)

Parts List:

- 1 Right Ascension (R.A.) Encoder housing (black anodized)
- 1 Declination (Dec.) Encoder housing (black anodized)
- 1 R.A. Axis Adapter (clear anodized - silver colored), labeled R.A.
- 1 Dec. Axis Adapter (clear anodized - silver colored), labeled Dec.

To install your encoders, first remove the telescope from your mount. Remove your declination counter weight(s) and declination counterweight shaft.

Fitting Declination Encoder Housing

If the encoders were purchased with the 1200 mount, it is likely that the declination axis adapter and encoder housing have already been installed. No further action will be required as this encoder will remain in place.

1. If the encoders were purchased separately, the silver-colored Dec. axis adapter may be inside the black Dec. axis encoder housing. If it is, remove it now.
2. Locate the counterweight shaft adapter (the black anodized part that the counterweight threads into) on the Dec. axis. When we assembled the mounts, we threaded this on rather tightly, so you will need some extra leverage to remove it. Locate the hole that was drilled into the part and find some object that you can insert. We suggest that you use one of your allen head wrenches that is wrapped in masking tape so that you do not mar the finish of the part. You may need to apply a good deal of force so it may be easiest to do if the mount is on the pier so that it won't move.
3. Thread the Dec. axis adapter into the end of your Dec. axis. Final tightening should be done with firm hand pressure. Normally the Dec. axis adapter will not be removed.
4. If you look into the black encoder housing, you will see the encoder itself mounted at the rear of the housing. When this installation procedure is complete, the encoder shaft will insert into the center hole of the Dec. axis adapter. This allows the encoder to read the motion of the declination shaft as the declination axis moves.
5. Thread the Dec. encoder housing onto the Dec. axis housing of the 1200 mount. You may need to wiggle the encoder housing gently to engage the shaft of the encoder with the hole in the center of the Dec. axis adapter. When the threading is complete, tighten up with firm hand pressure (or insert your special "tool" from above and tighten firmly) since normally this encoder housing will not be removed.
6. The counterweight shaft may now be rethreaded into the rear of the Dec. encoder housing.

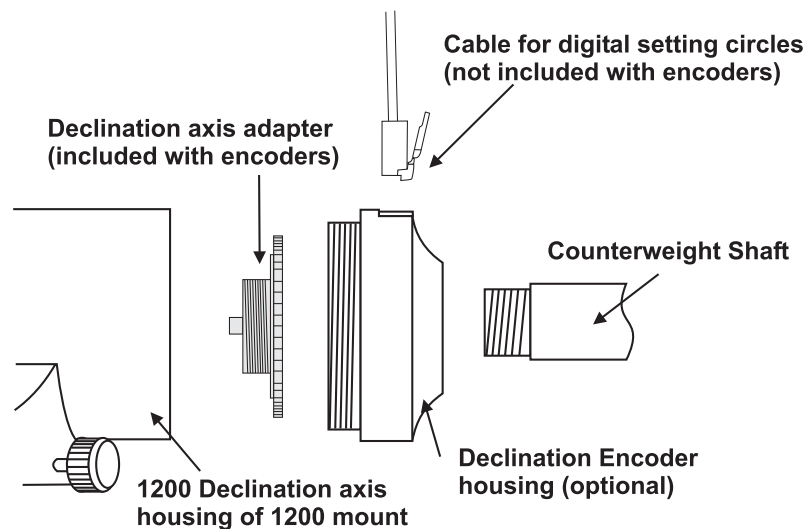

Diagram 15

Fitting Right Ascension Encoder Housing

If the encoders were purchased with the 1200 mount, it is likely that the right ascension axis adapter and encoder housing have already been installed. Please continue to read these directions since you may need to remove and reinstall the encoders if you use a polar alignment scope. Since the polar axis telescope and R.A. axis adapter thread into the same location, you will need to switch back and forth between them as needed. If you use the JMI NGC MAX or Mini MAX Digital Setting Circles, you can use the "polar align" mode in these units instead of a polar alignment scope!

1. If the encoders were purchased separately, the silver-colored R.A. axis adapter may be inside the R.A. axis encoder housing. If it is, remove it now.
2. Thread the R.A. axis adapter into the end of your R.A. axis (if your polar alignment scope is fitted you must remove this first along with the polar alignment scope adapter). Use moderate hand pressure to tighten the R.A. adapter since you may need to remove it to install the polar axis telescope at a later time.
3. If you look into the black encoder housing, you will see the encoder itself mounted at the rear of the housing. When this installation procedure is complete, the encoder shaft will insert into the center hole of the R.A. axis adapter. This allows the encoder to read the motion of the R.A. shaft as the right ascension axis moves.
4. Now thread the R.A. encoder housing onto the R.A. axis housing. You may need to wiggle the encoder housing gently to engage the shaft of the encoder (located within the R.A. axis housing) with the hole in the center of the R.A. axis adapter. Again, use moderate hand pressure as you may wish to remove this at some time.
5. The hardware for your encoders is now installed. For actual set-up procedures for Micro MAX, Mini MAX or NGC MAX, digital readouts refer to the relevant operating manual from the manufacturer. We provide some startup tips

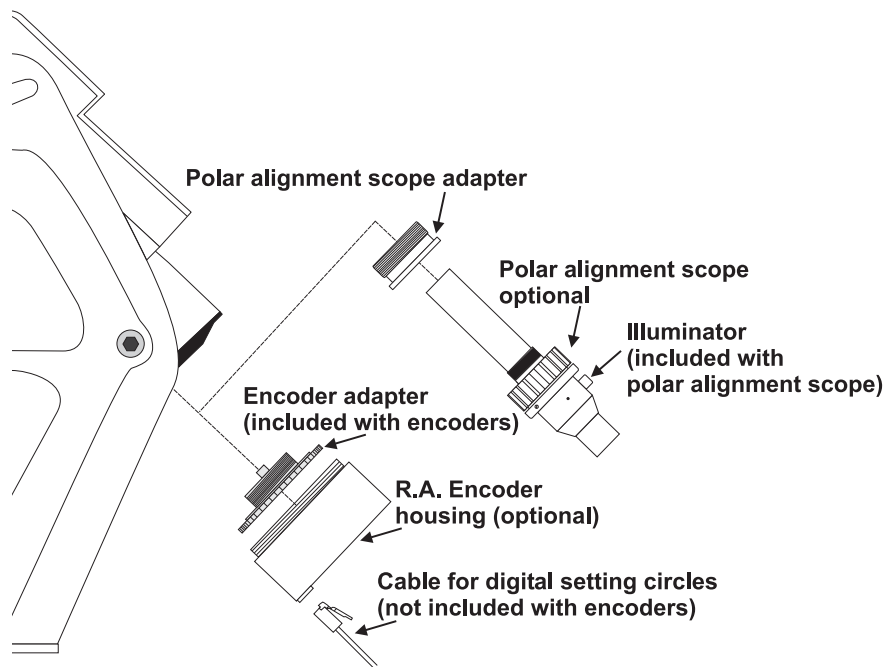

Diagram 16

in our instruction sheet entitled "Using JMI Setting Circles".

Periodic Maintenance

If you remove the R.A. encoder frequently, you may wish to use a very tiny amount of auto grease on the mating threads.